

## FLO SERIES

PART NUMBER: SA-EL-1MU

### Loader & Unloader Single Magazine Unloader

The unloader modules are used for the automatic unloading of Bare or Assembled PCBs from SMD lines.

Pick and Place, screen printers, reflow ovens, or test system can be interfaced with it.



### Layout Module

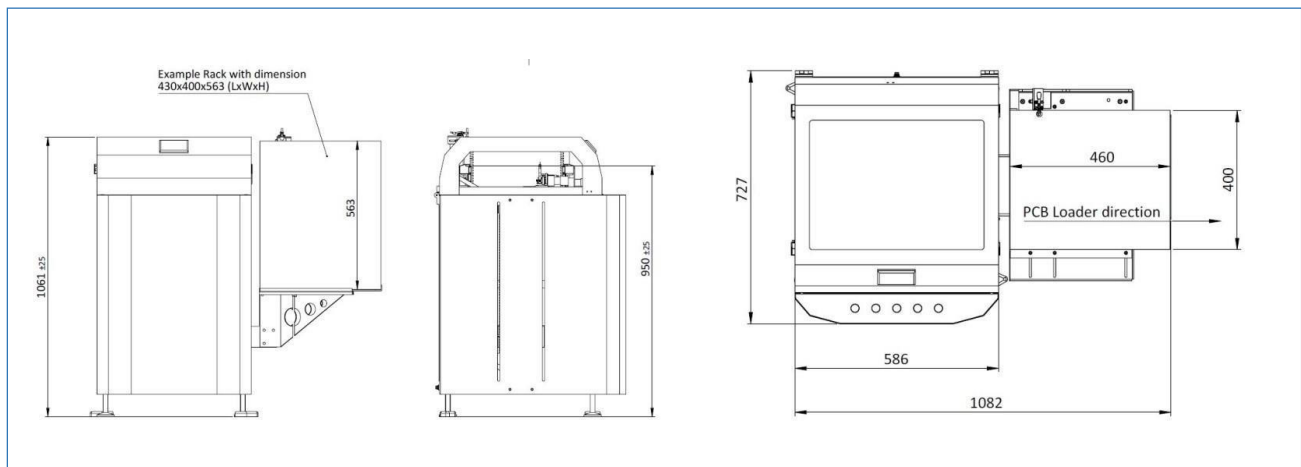

## FLO SERIES GENERAL FEATURES

|                            |   |
|----------------------------|---|
| <b>TRANSPORT</b>           |   |
| <b>Height:</b>             | 950 mm +/- 25 mm  |
| <b>Width:</b>              | Min. 70 mm – Max 350 mm   |
| <b>PCB edge space:</b>     | Min. 3 mm   |
| <b>Transfer direction:</b> | Left to right   |
| <b>Operating side:</b>     | Front of the machine  |
| <b>Fixed Rail:</b>         | Front of the machine  |
| <b>Interface:</b>          | Std. or Extd. SMEMA<br>Opt Fuji, Panasonic, Sanyo, Siemens, SMPI, Special |
| <b>SMEMA cable length:</b> | 3 m   |

|                                   |  |
|-----------------------------------|--|
| <b>PANEL DIMENSION</b>            |  |
| <b>Length:</b>                    | Min. 100 mm – Max 450 mm                         |
| <b>Width:</b>                     | Min. 70 mm – Max 350 mm                          |
| <b>Thickness:</b>                 | From 0.8 mm to 4.0 mm                            |
| <b>Component clearance:</b>       | Top: 40 mm Bottom: 20 mm                         |
| <b>PCB max weight:</b>            | 1 Kg   |
| <b>Max dimension of the rack:</b> | L 460 x W 440 x H 570 (mm) External Measurements |

### VARIOUS:

- CE safety compliant
- PLC microprocessor driven system
- Mechanical keyboard or LCD display
- Single piece aluminium rails, proprietary design

**POWER SUPPLY:** 230V 1Ph+N+G 50Hz

**CURRENT:** 2 Ampere

**WEIGHT:** 90 Kg

**DIMENSION LxWxH:** 1.100x750x1.500 mm (Rack Homing)

**COLOR:** RAL 7035

**TRANSPARENT COVER:** STANDARD (NOT ESD)

*All modules are ESD compliant and CE marked, each module has an independent control system. Technical specification may change without any advanced notice.*



[www.seica-automation.it](http://www.seica-automation.it)

sales@seica-automation.com

info@seica-automation.com

+39 0362 1572 717

**Seica Automation s.r.l**

Via Sardegna, 4 20841

Carate Brianza (MB) ITALY

P.iva / C.F. 11044290010