

FLO SERIES

PART NUMBER: SA-EL-2MU

Loader & Unloader

Double Magazine Unloader

The unloader modules are used for the automatic unloading of PCBs from SMD lines.

Internal shuttle and 2 independent lifters (1 x Rack).

This module could be used also for Good/Bad PCB separation.

Programmable display.



Layout Module

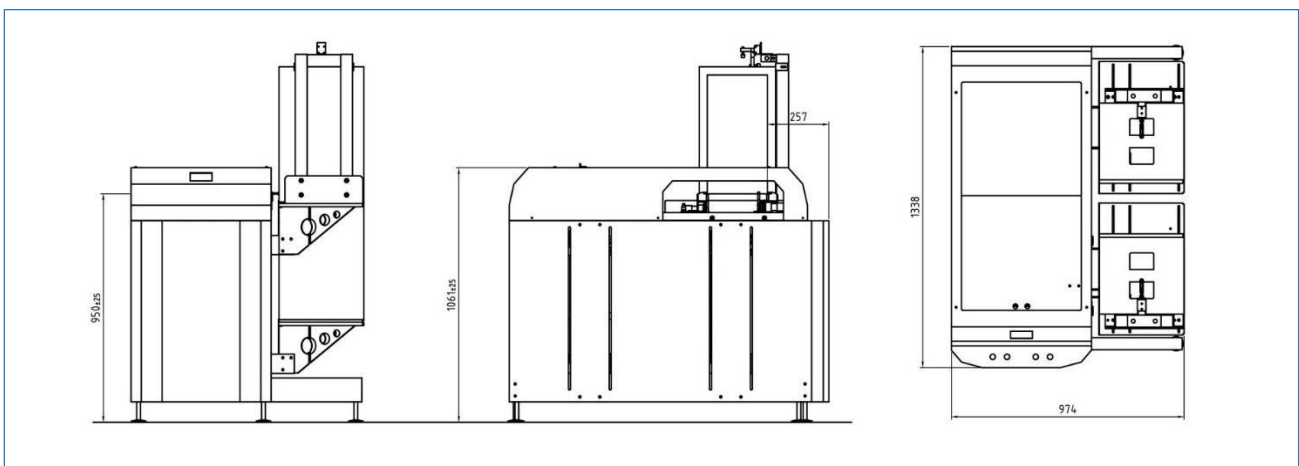

FLO SERIES GENERAL FEATURES

TRANSPORT	
Height:	950 mm +/- 25 mm
Width:	Min. 70 mm – Max 350 mm
PCB edge space:	Min. 3 mm
Transfer direction:	Left to right
Operating side:	Front of the machine
Fixed Rail:	Front of the machine
Interface:	Std. or Extd. SMEMA Opt Fuji, Panasonic, Sanyo, Siemens, SMPI, Special
SMEMA cable length:	3 m

PANEL DIMENSION	
Length:	Min. 100 mm – Max 450 mm
Width:	Min. 70 mm – Max 350 mm
Thickness:	From 0.8 mm to 4.0 mm
Component clearance:	Top: 40 mm Bottom: 20 mm
PCB max weight:	1 Kg
Max dimension of the rack:	L 460 x W 440 x H 570 (mm) External Measurements

VARIOUS:

- CE safety compliant
- PLC microprocessor driven system
- Mechanical keyboard or LCD display
- Single piece aluminium rails, proprietary design

POWER SUPPLY:

230V 1Ph+N+G 50Hz

CURRENT:

3.5 Ampere

WEIGHT:

200 Kg

AIR SUPPLY:

0.6 Mpa

DIMENSION LxWxH:

1.100x1.350x1.500 mm (rack homing)

COLOR:

RAL 7035

TRANSPARENT COVER:

Standard (NOT ESD)

All modules are ESD compliant and CE marked, each module has an independent control system. Technical specification may change without any advanced notice.

