

FLO SERIES

PART NUMBER: SA-EL-BBD

Loader & Unloader Bare Board Destacker

The Bare Board Destacker modules are used for the automatic loading of stacked bare boards for an automatic line like, screen printers or bare boards testers, label applicators, laser marking. BBD allows simple manual adjust of conveyor.



Layout Module

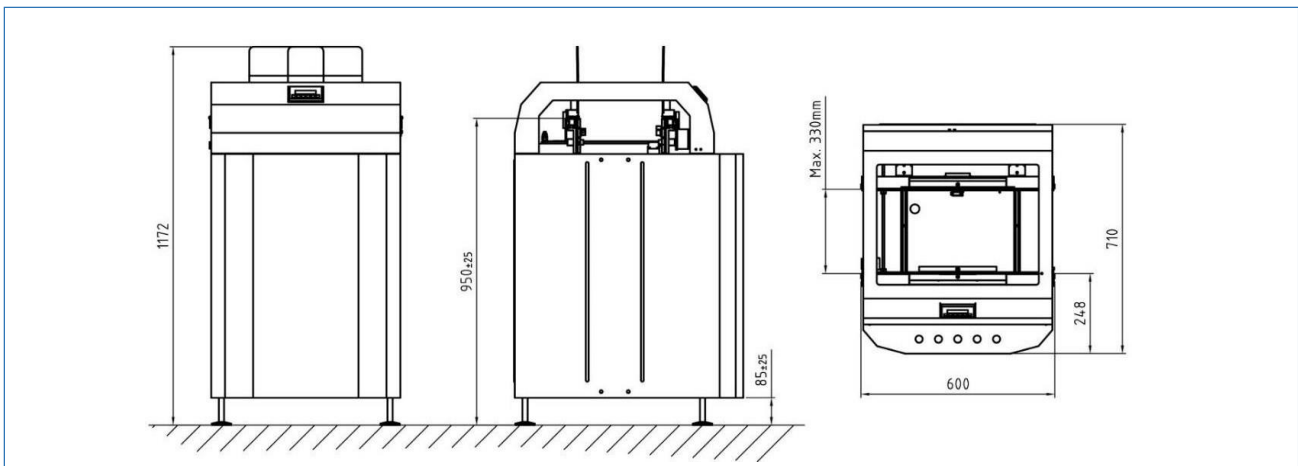

FLO SERIES GENERAL FEATURES

TRANSPORT	
Height:	950 mm +/- 25 mm
Width:	Min. 70 mm – Max 350 mm
PCB edge space:	Min. 3 mm
Transfer direction:	Left to right
Operating side:	Front of the machine
Fixed Rail:	Front of the machine
Interface:	Std. or Extd. SMEMA Opt Fuji, Panasonic, Sanyo, Siemens, SMPI, Special
SMEMA cable length:	3 m

PANEL DIMENSION	
Length:	Min. 100 mm – Max 450 mm
Width:	Min. 70 mm – Max 350 mm
Thickness:	From 0.8 mm to 4.0 mm
Component clearance:	Top: 40 mm Bottom: 20 mm
PCB max weight:	1 Kg
Max stack height:	180 mm, max 12 Kg

VARIOUS:

- CE safety compliant
- PLC microprocessor driven system
- Mechanical keyboard or LCD display
- Single piece aluminium rails, proprietary design

POWER SUPPLY: 230V 1Ph+N+G 50Hz

CURRENT: 2 Ampere

AIR SUPPLY: 0.6 Mpa

WEIGHT: 90 Kg

DIMENSION LxWxH: 600x750x1.400 mm

COLOR: RAL 7035

All modules are ESD compliant and CE marked, each module has an independent control system. Technical specification may change without any advanced notice.