

FLEX SERIES

PART NUM: SA-FC-1ML-XL

LOADER & UNLOADER

Single Magazine Loader

The XL loader module is used to load EXTRA SIZE PCB (Up to 610 mm length). Additional sensors and custom Pusher are included. Pick and Place, screen printer Reflow Oven Test system can be interfaced to it.

Imagery for illustration purposes only. Please consult your local Seica Automation distributor for more information.



Layout Module

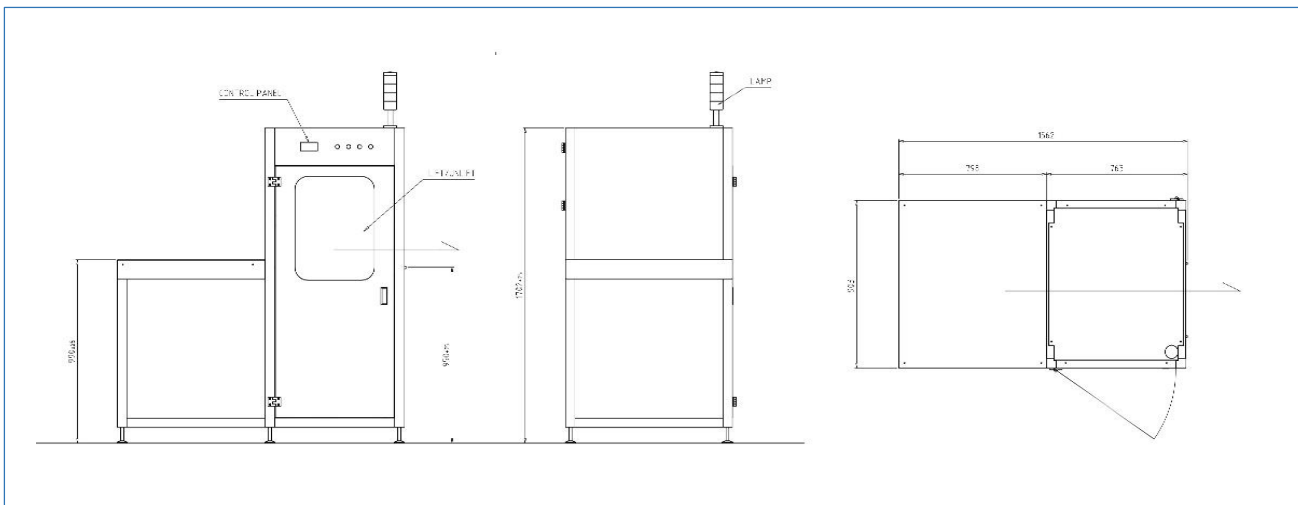

FLEX SERIES GENERAL FEATURES

TRANSPORT	
Height:	950 mm +/- 25 mm
Width:	Min. 85 mm – Max 390 mm
PCB edge space:	Min. 3 mm
Transfer direction:	Left to right
Operating side:	Front of the machine
Fixed Rail:	Front of the machine
Interface:	SMEMA standard extended SMEMA Optional Fuji, Panasonic, Sanyo, Siemens, SMPI, Special
SMEMA cable length:	3 m

PANEL DIMENSION	
Length:	Min. 80 mm – Max 610 mm
Width:	Min. 85 mm – Max 390 mm
Optional width:	Up to 460 mm on request
Thickness:	From 0.8 mm to 4.0 mm
PCB max weight:	15 Kg

VARIOUS:

- CE safety compliant
- PLC microprocessor driven system
- Mechanical keyboard or LCD display
- Automatic control of limit reached
- Single piece aluminium rails, proprietary design

POWER SUPPLY: 230V 1Ph+N+G 50Hz

CURRENT: 2 Ampere

AIR SUPPLY: 0,6 Mpa

WEIGHT: 130 Kg

DIMENSION LxWxH: 1.562x903x1.727 mm

COLOR: RAL 7035

FRAME: Aluminium profiles

All modules have ESD safe design and CE mark, each module has independent control system. Technical specification may change without any advice, please contact our representative office.



www.seica-automation.it

sales@seica-automation.com
info@seica-automation.com
+39 0362 15 72 717

Seica Automation s.r.l
Via Arturo Toscanini, 50-52
20831 Seregno (MB) ITALY
P.iva / C.F. 11044290010