

FLEX SERIES

PART NUM: SA-FC-BUF-FFB

FIFO LIFO BELT BUFFER

FIFO – LIFO Fast Buffer – 25 Independent Belt Slot

FIFO-LIFO Buffer with 25 Independent belt slots. This module is the faster buffer of FLEX series. Used in High Speed SMT lines where the FIFO function combined with high speed require a small cycle time for PCB transferring. Additional Integrate Conveyor as option.

Optional:

- Hand crank width adjust included

Imagery for illustration purposes only. Please consult your local Seica Automation distributor for more information.



SA-FC-BUF-FFB with integrated LC1S

Layout Module

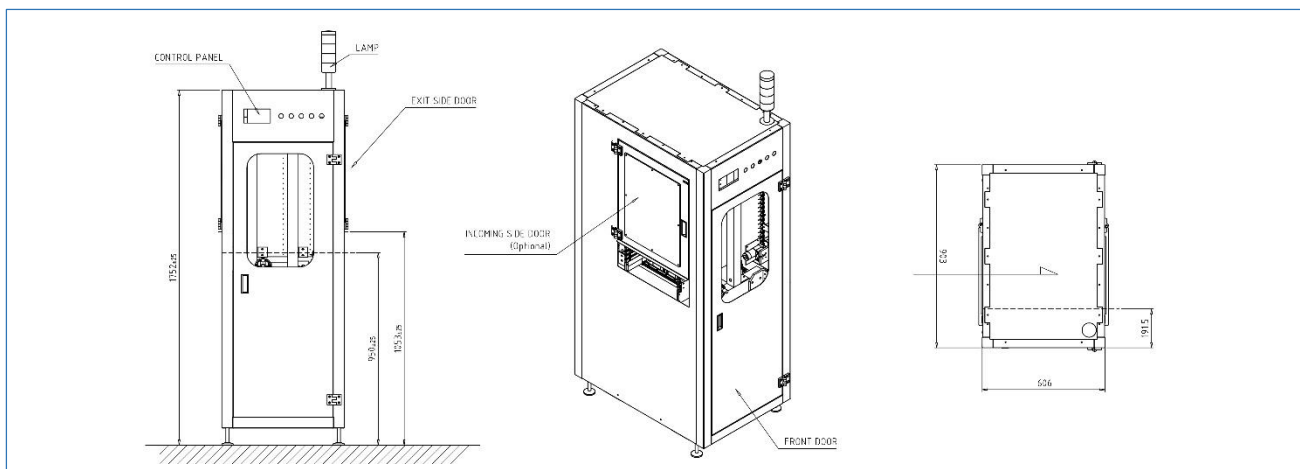

FLEX SERIES GENERAL FEATURES

TRANSPORT	
Height:	950 mm +/- 25 mm
Component clearance:	Top 50 mm (80 mm on request) Bottom 30 mm (80 mm on request)
PCB edge space:	Min. 3 mm
Transfer direction:	Left to right
Operating side:	Front of the machine
Fixed Rail:	Front of the machine
Interface:	SMEMA standard extended SMEMA Optional Fuji, Panasonic, Sanyo, Siemens, SMPI, Special
SMEMA cable length:	3 m

PANEL DIMENSION	
Length:	Min. 80 mm – Max 510 mm
Width:	Min. 85 mm – Max 390 mm
Optional width:	Up to 460 mm on request
Thickness:	From 0.8 mm to 4.0 mm
PCB max weight:	2 Kg

VARIOUS:

- CE safety compliant
- PLC microprocessor driven system
- Mechanical keyboard or LCD display with keyboard operation
- Automatic Width Adjust as option
- Single piece aluminium rails, proprietary design

POWER SUPPLY:

230V 50Hz 1+N+T

CURRENT:

2 Ampere

AIR SUPPLY:

0,6 Mpa

WEIGHT:

180 Kg

DIMENSION LxWxH:

606x903x1.752 mm

COLOR:

RAL 7035

FRAME:

Aluminium profiles

All modules are ESD compliant and CE marked, each module has an independent control system. Technical specification may change without any advanced notice.

