

FLEX SERIES

PART NUM: SA-FC-LCO1S

LINKING CONVEYOR – INFEED-OUTFEED - REFLOW OVEN

Linking Conveyor Outfeed 1 Segment

Used to pass PCB from SMT Line to Reflow Oven.
Adjustable speed for easy transfer of PCBs at the front of reflow Oven.

The module is composed of a single segment from 500mm up to 1.000mm (Standard length 600mm).

Standard Linking Conveyor include:

- Cover (without micro switch)
- Speed 200 mm/sec

Imagery for illustration purposes only. Please consult your local Seica Automation distributor for more information.



Layout Module

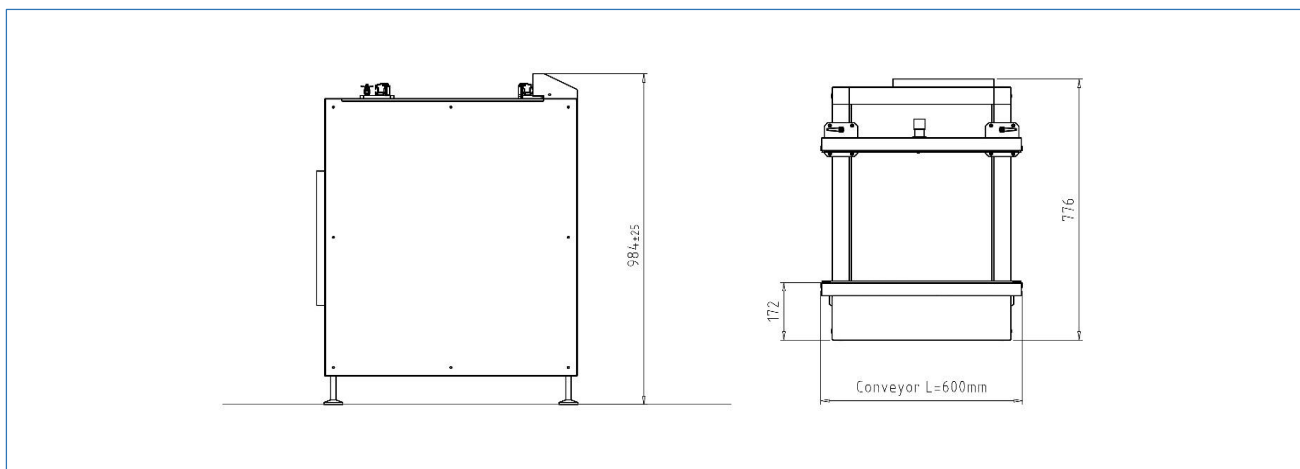

FLEX SERIES GENERAL FEATURES

TRANSPORT	
Height:	950 mm +/- 25 mm
Component clearance:	Top 50 mm (80 mm on request) Bottom 30 mm (80 mm on request)
Width:	Min. 50 mm – Max 390 mm
PCB edge space:	Min. 3 mm
Transfer direction:	Left to right
Operating side:	Front of the machine
Fixed Rail:	Front of the machine
Interface:	SMEMA standard. Optional Fuji, Panasonic, Sanyo, Siemens, SMPI, Special
SMEMA cable length:	3 m

PANEL DIMENSION	
Length:	Min. 80 mm – Max 510 mm
Width:	Min. 50 mm – Max 390 mm
Optional width:	Up to 460 mm on request
Thickness:	From 0.8 mm to 4.0 mm
PCB max weight:	2 Kg

VARIOUS:

- CE safety compliant
- PLC microprocessor driven system
- Automatic Width Adjust as option
- Single piece aluminium rails, proprietary design

POWER SUPPLY:

230V 50Hz 1+N+T

CURRENT:

1 Ampere

AIR SUPPLY:

No Air Required

WEIGHT:

70 Kg

DIMENSION LxWxH:

600x776x1.052 mm

COLOR:

RAL 7035

FRAME:

Aluminium profiles

All modules are ESD compliant and CE marked, each module has an independent control system. Technical specification may change without any advanced notice.